

BIELA14-T Series

Gen III LOV™ Electric Fryer



Wiring Diagrams

This manual is updated as new information and models are released. Visit our website at www.frymaster.com for the latest manual. This equipment chapter is to be installed in the Fryer Section of the *Equipment Manual*.



Part Number: FRY_D_8197343 05/2016

 DANGER

Improper installation, adjustment, maintenance or service, and unauthorized alterations or modifications can cause property damage, injury, or death. Read the installation, operating, and service instructions thoroughly before installing or servicing this equipment.

 DANGER

This fryer has a power cord (three-phase) for each frypot and a single five-wire cord for the entire system. Prior to movement, testing, maintenance and any repair on your Frymaster fryer; disconnect ALL electrical power cords from the electrical power supply.

BIELA14-T SERIES GEN III LOV™ ELECTRIC FRYER
Table of Contents

SECTION 1: Wiring Diagrams

- 1.1 BIELA14-T Series GEN III LOV™ Simplified Wiring 1-1
- 1.2 BIELA14-T Series GEN III LOV™ Control Wiring 1-2
- 1.3 FIB (Filtration Interface Board) Wiring 1-3
- 1.4 Contactor Box-Delta Configuration 1-4
- 1.5 Solid Shortening Melting Unit Wiring 1-5

BIELA14-T SERIES GEN III LOV™ ELECTRIC FRYER

SECTION 8: WIRING DIAGRAMS

1.1 BIELA14-T Series GEN III LOV™ Simplified Wiring

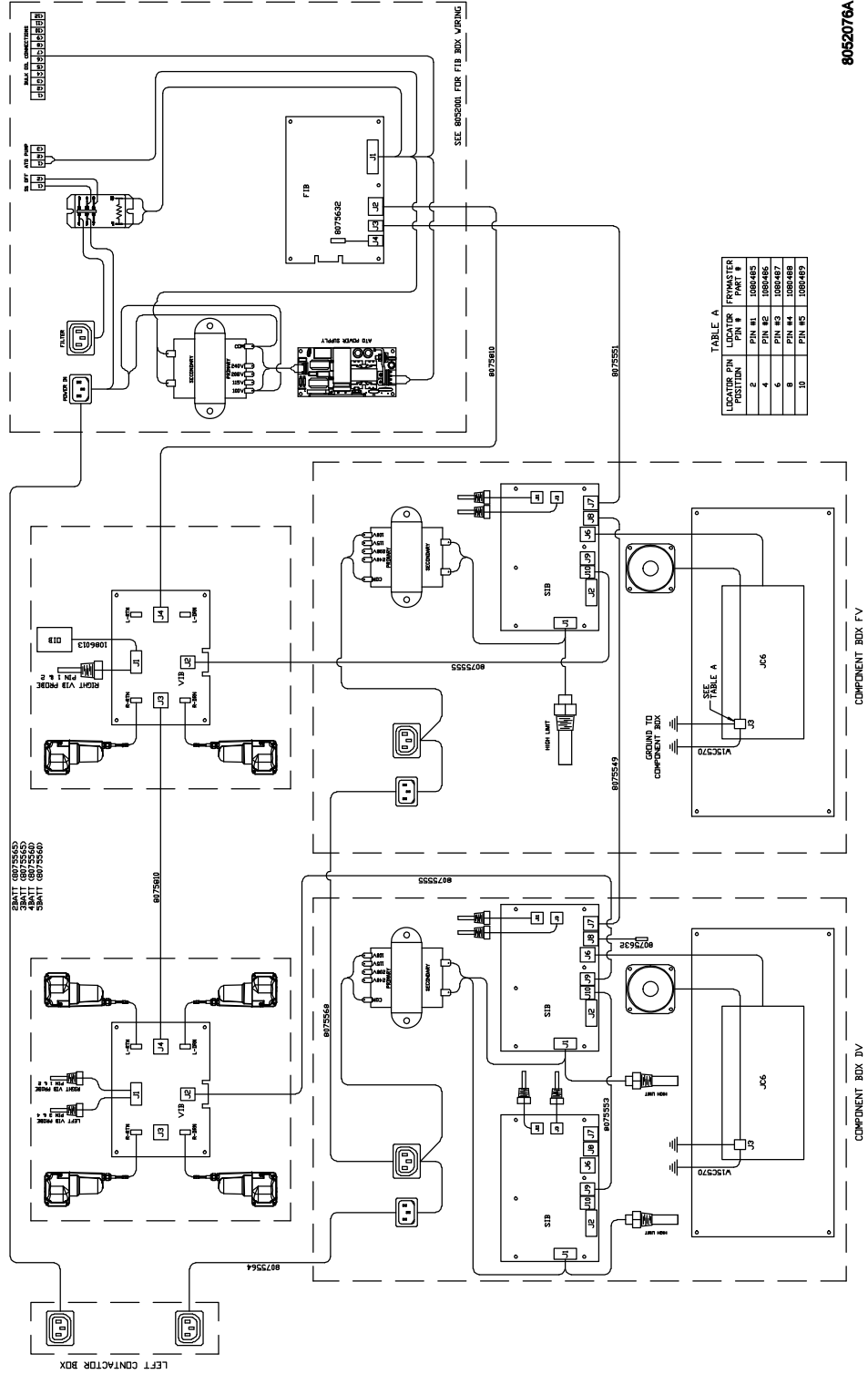

8052076A

1.2 BIELA14-T Series GEN III LOV™ Control Wiring

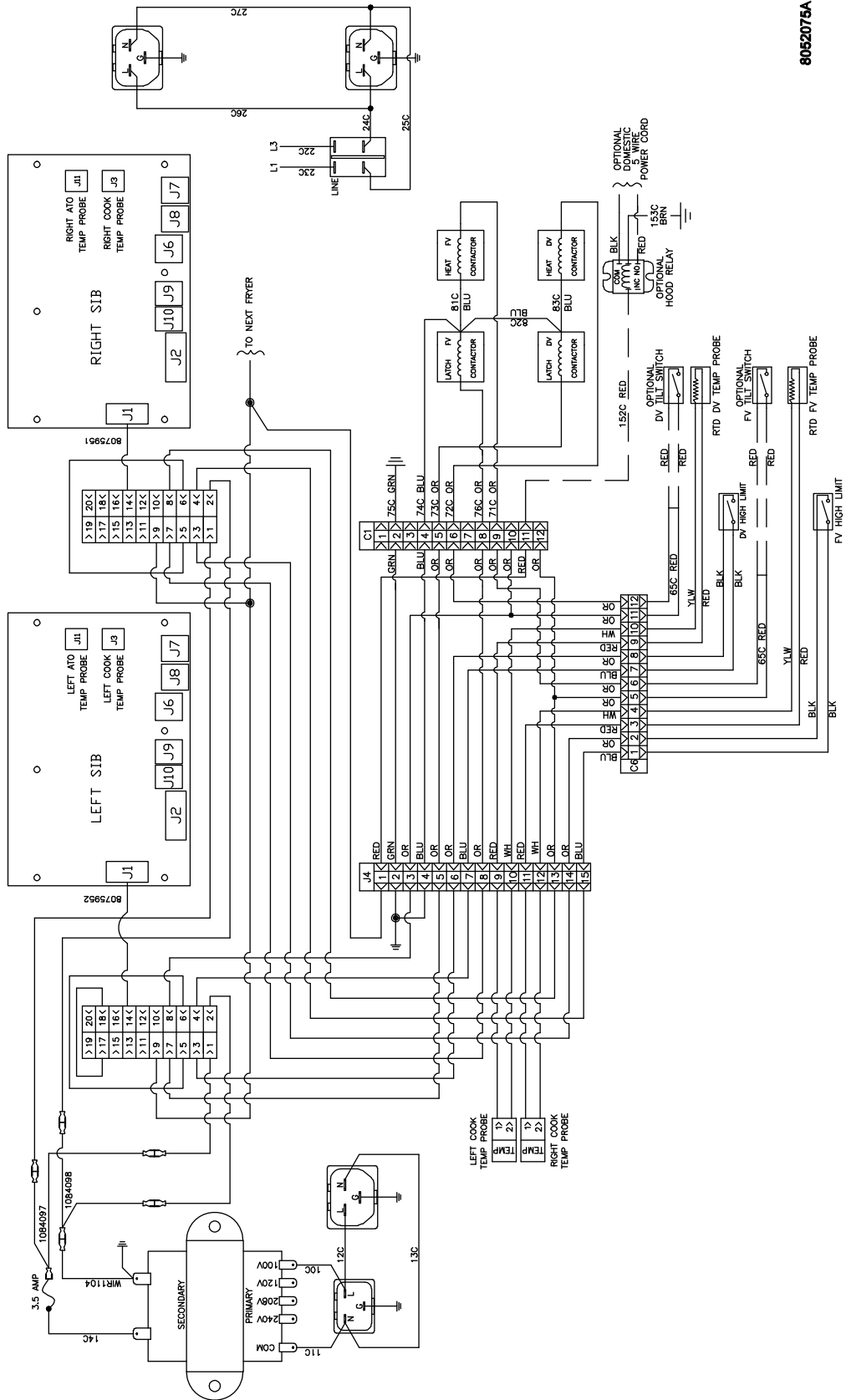

8052075A

1.3 FIB (Filtration Interface Board) Wiring

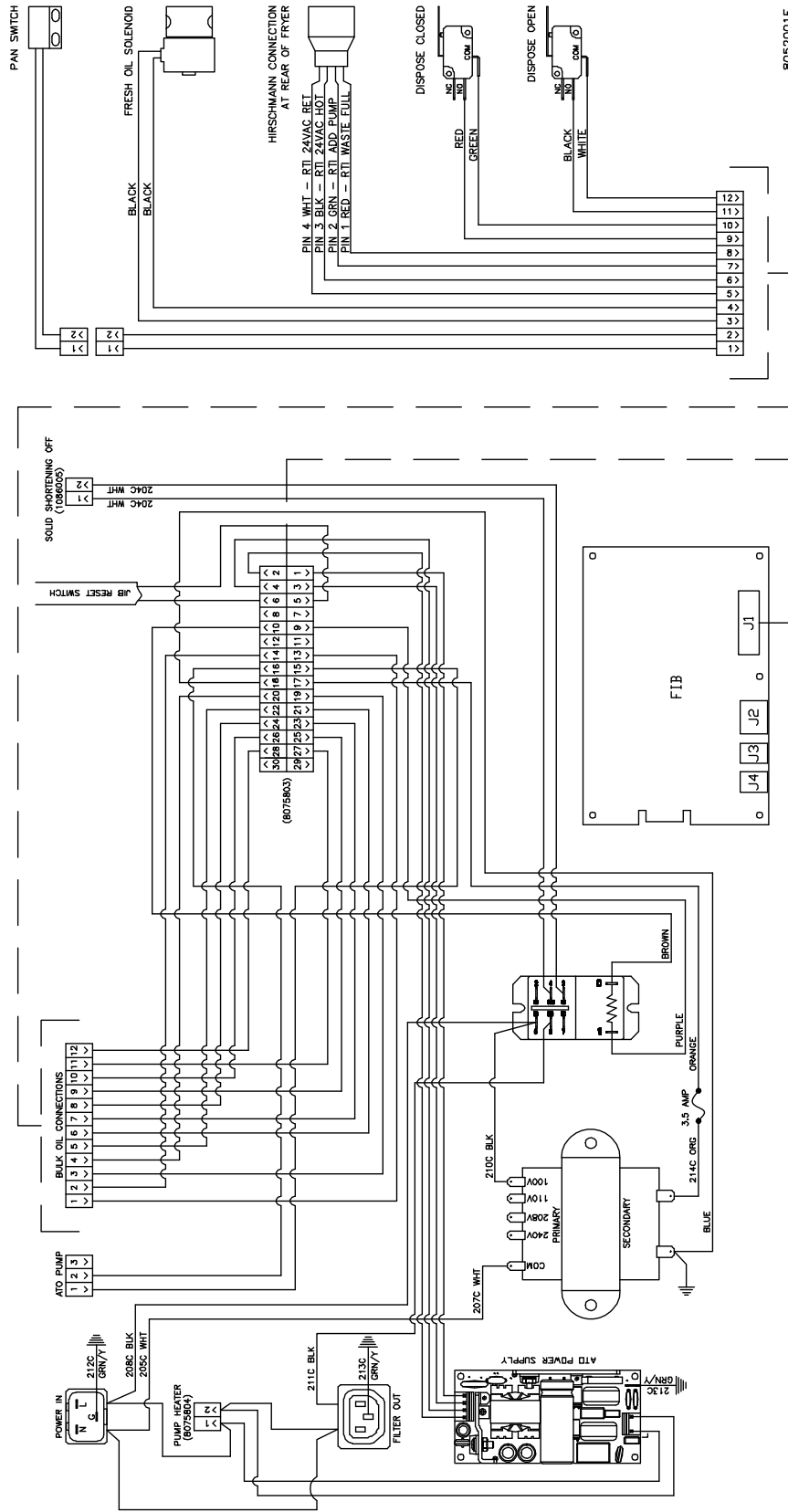

1.4 Contactor Box – Delta Configuration

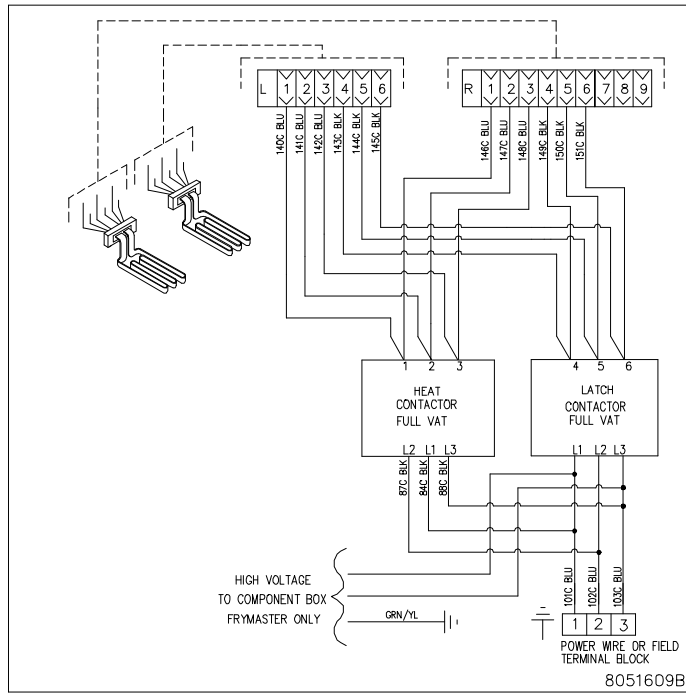

FULL VAT

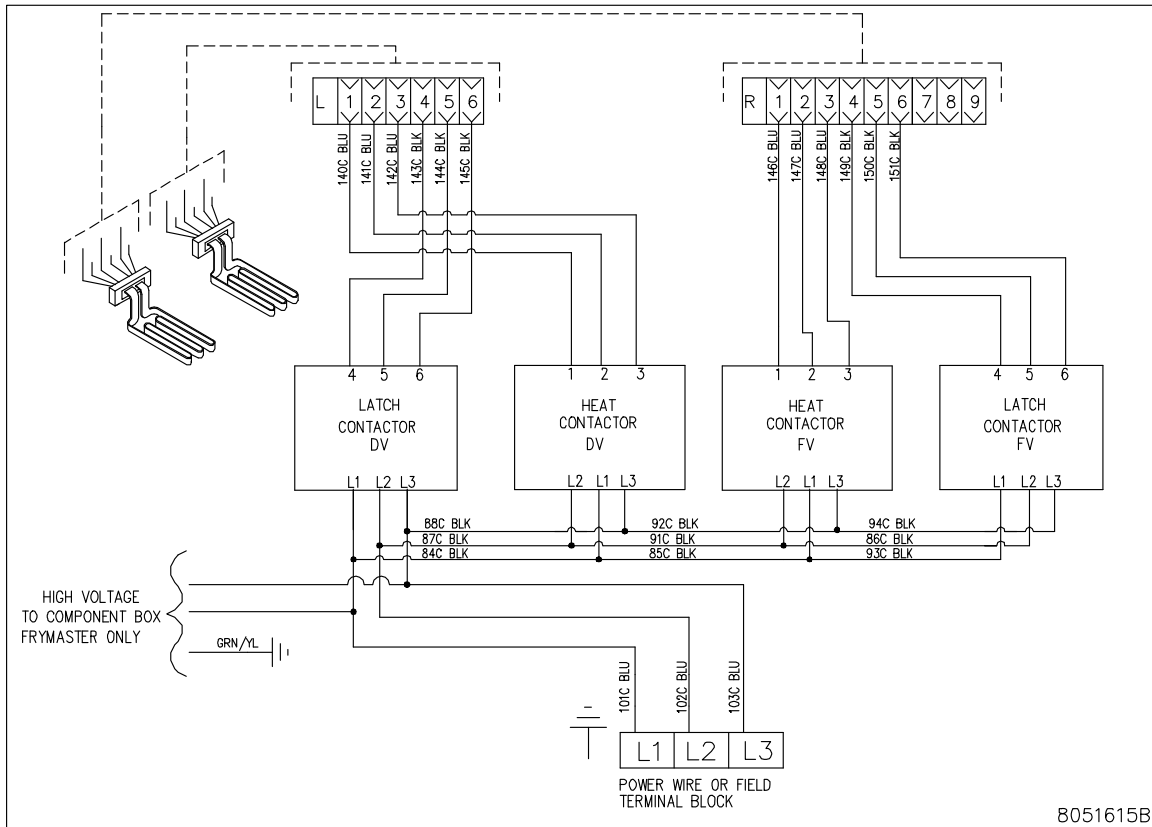

DUAL VAT

8051615B

1.5 Solid Shortening Melting Unit Wiring

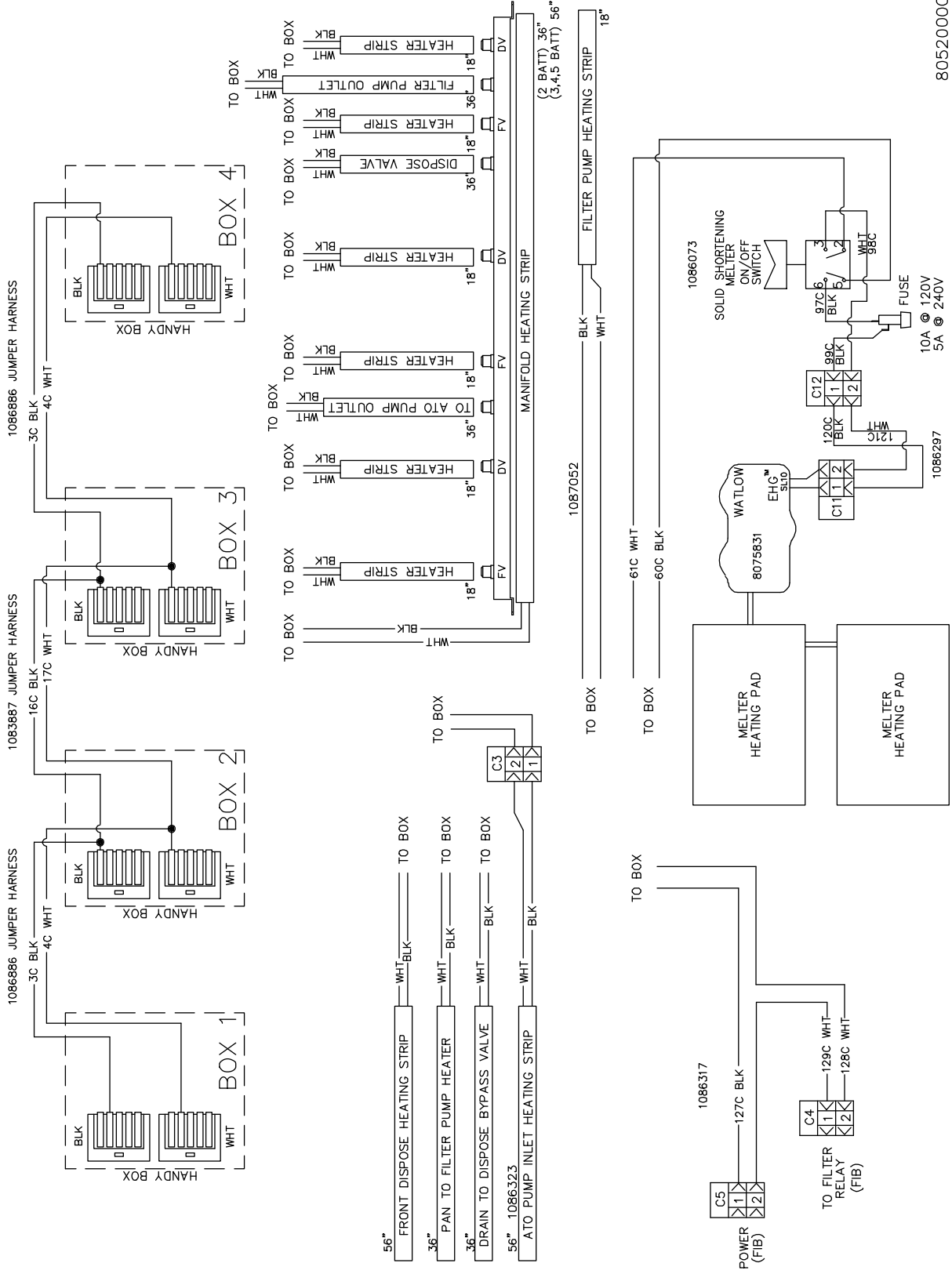

8052000G

THIS PAGE INTENTIONALLY LEFT BLANK



FRYMASTER
8700 LINE AVENUE, SHREVEPORT, LA 71106-6800

318-865-1711
800-551-8633
844-724-CARE (2273)
WWW.FRYMASTER.COM
EMAIL: SERVICE@FRYMASTER.COM



Every new piece of Manitowoc Foodservice equipment comes with KitchenCare™ and you choose the level of service that meets your operational needs from one restaurant to multiple locations.

StarCare – Warranty & lifetime service, certified OEM parts, global parts inventory, performance audited

ExtraCare – CareCode, 24/7 Support, online/mobile product information

LifeCare – Install & equipment orientation, planned maintenance, KitchenConnect™, MenuConnect

Talk with KitchenCare™ - 1-844-724-CARE - www.mtwkitchencare.com



To learn how Manitowoc Foodservice and its leading brands can equip you, visit our global web site at www.manitowocfoodservice.com, then discover the regional or local resources available to you.

